

CS 343: Artificial Intelligence

Decision Networks and Value of Perfect Information

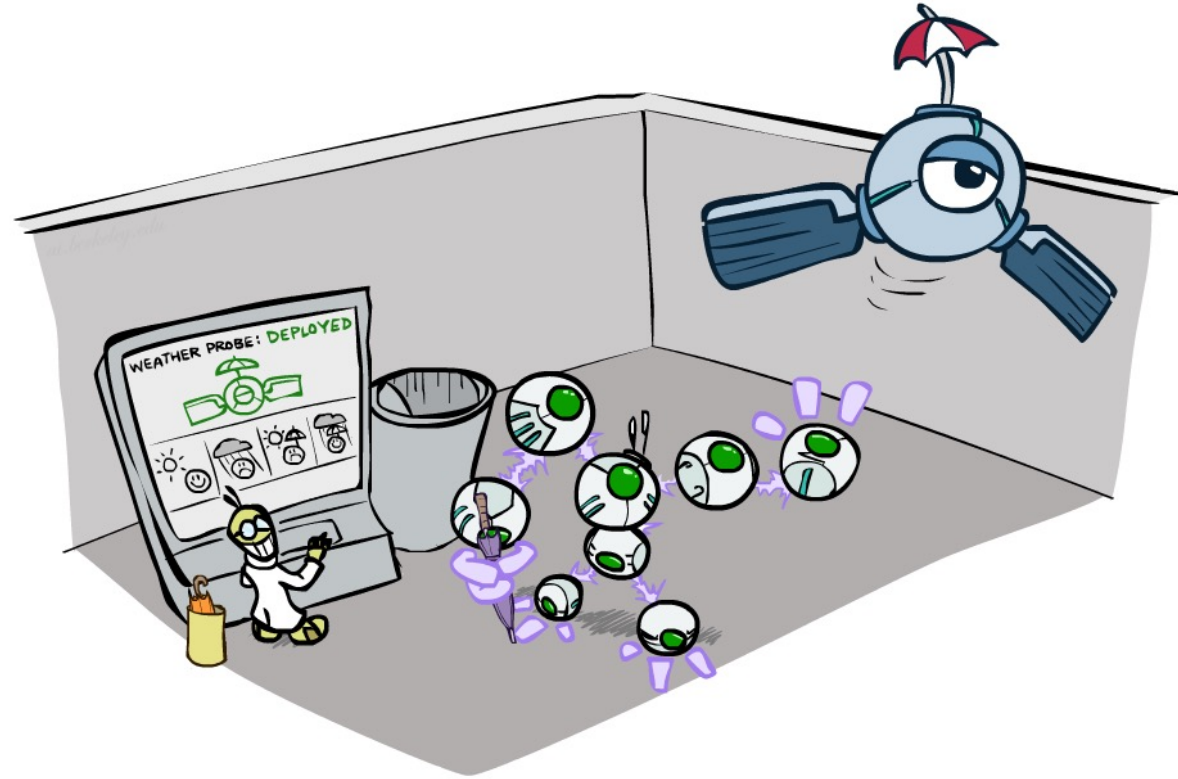

Prof. Yuke Zhu — The University of Texas at Austin

Decision Networks

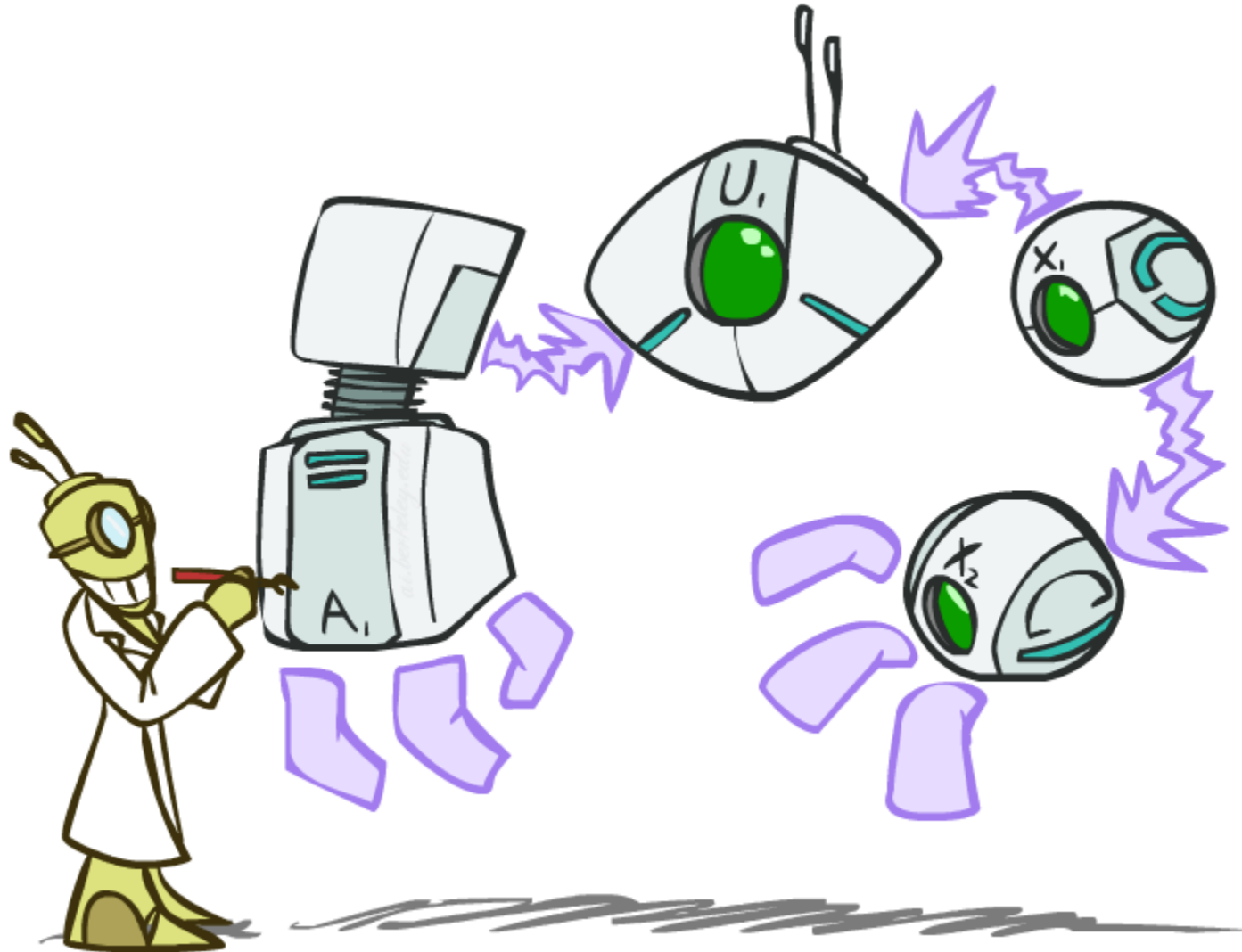

Decision Networks

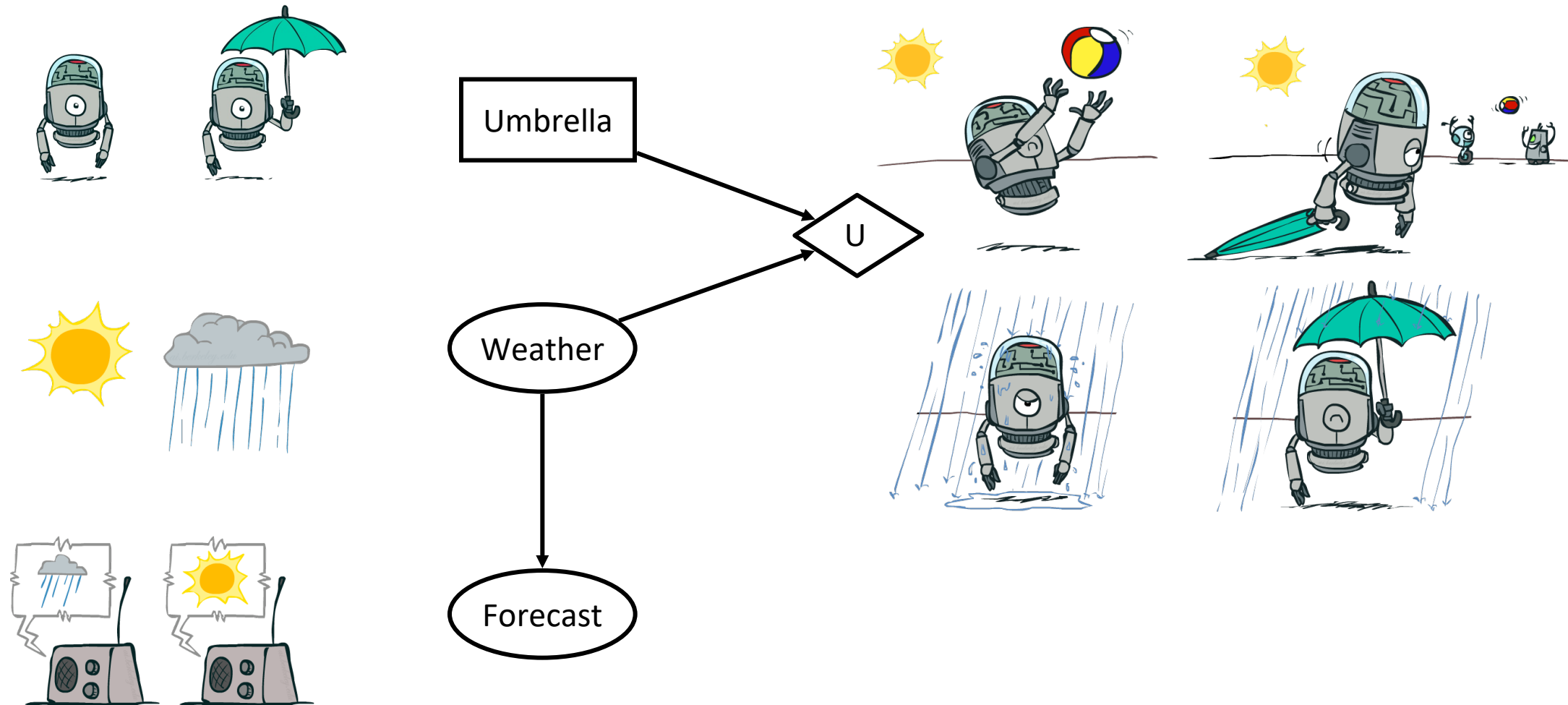

Decision Networks

- **MEU: choose the action which maximizes the expected utility given the evidence**
- Can directly operationalize this with decision networks
 - Bayes nets with nodes for utility and actions
 - Let us calculate the expected utility for each action
- New node types:

○ Chance nodes (just like BNs)

▭ Actions (rectangles, cannot have parents, act as observed evidence)

◇ Utility node (diamond, depends on action and chance nodes)

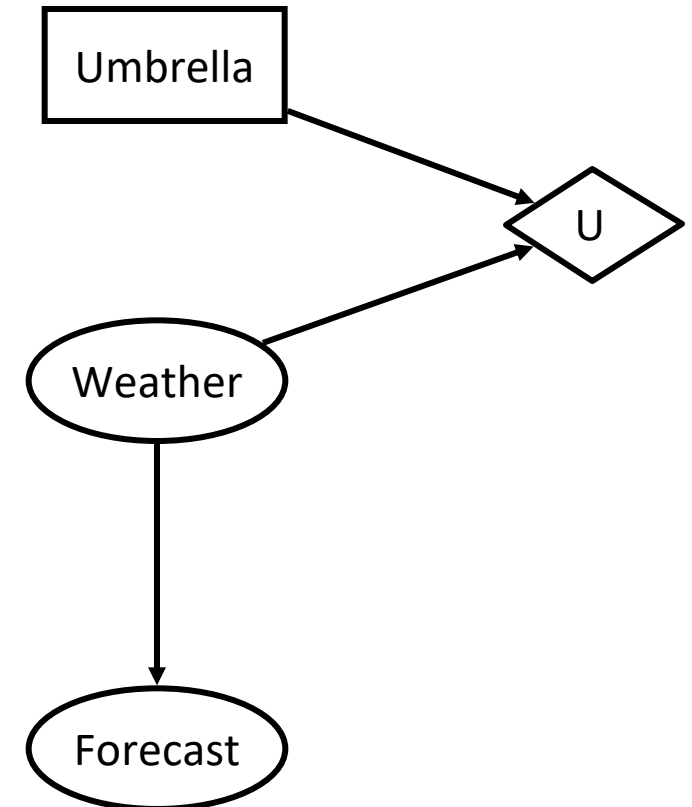

Decision Networks

- Action selection
 - Instantiate all evidence
 - Set action node(s) each possible way
 - Calculate posterior for all parents of utility node, given the evidence
 - Calculate expected utility for each action
 - Choose maximizing action

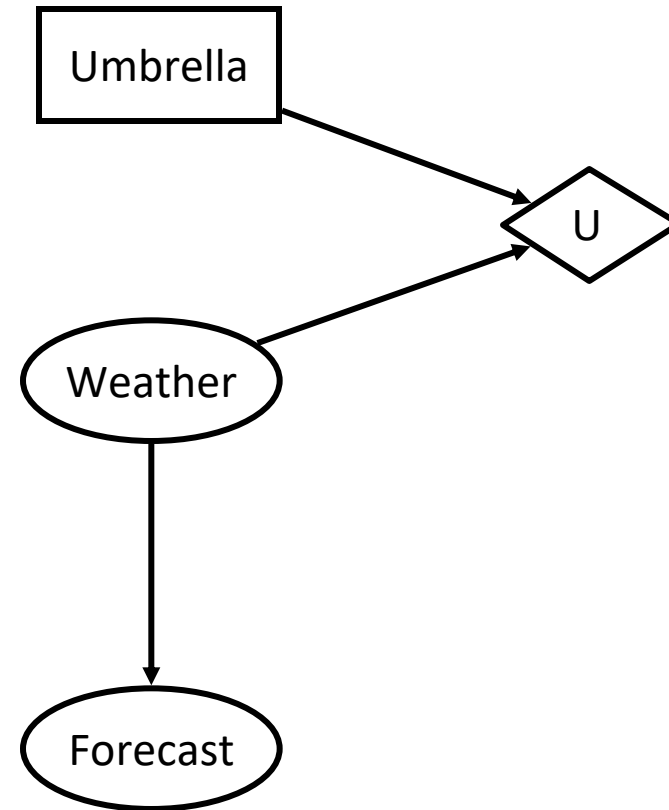

Decision Networks

Umbrella = leave

$$EU(\text{leave}) = \sum_w P(w)U(\text{leave}, w)$$

$$= 0.7 \cdot 100 + 0.3 \cdot 0 = 70$$

Umbrella = take

$$EU(\text{take}) = \sum_w P(w)U(\text{take}, w)$$

$$= 0.7 \cdot 20 + 0.3 \cdot 70 = 35$$

Optimal decision = leave

$$MEU(\emptyset) = \max_a EU(a) = 70$$

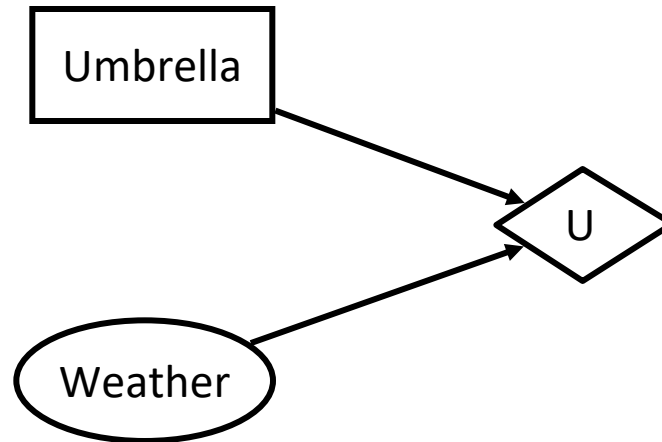

W	P(W)
sun	0.7
rain	0.3

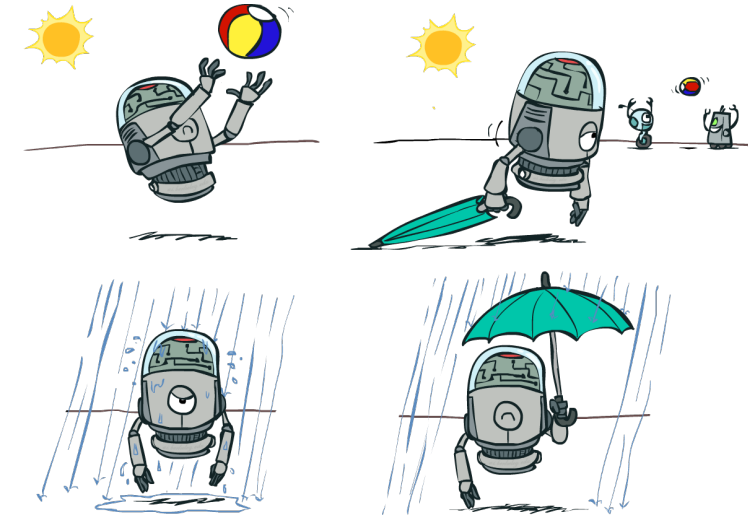

A	W	U(A,W)
leave	sun	100
leave	rain	0
take	sun	20
take	rain	70

Decisions as Outcome Trees

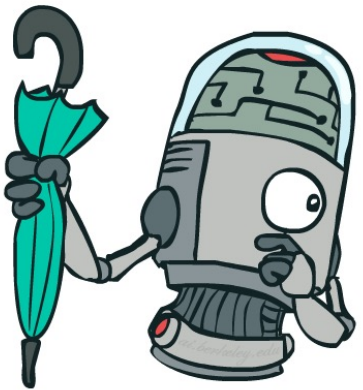
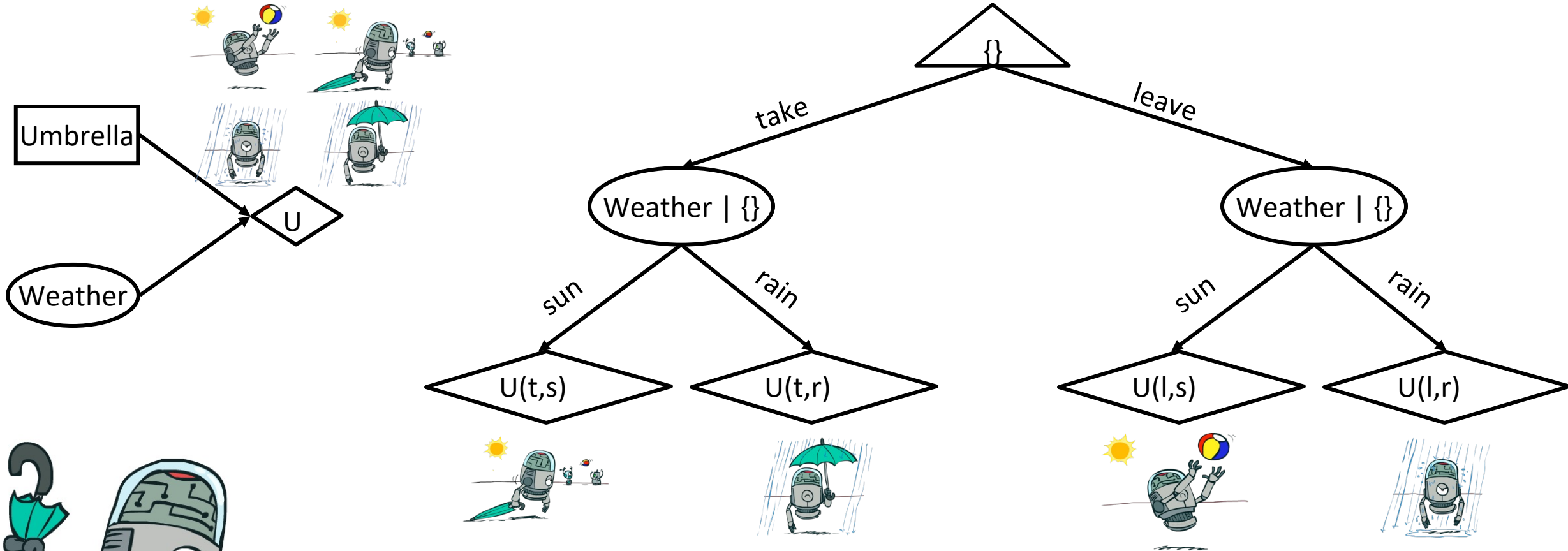

- Almost exactly like expectimax / MDPs
- What's changed?

Example: Decision Networks

Umbrella = leave

$$\begin{aligned} EU(\text{leave}|\text{bad}) &= \sum_w P(w|\text{bad})U(\text{leave}, w) \\ &= 0.34 \cdot 100 + 0.66 \cdot 0 = 34 \end{aligned}$$

Umbrella = take

$$\begin{aligned} EU(\text{take}|\text{bad}) &= \sum_w P(w|\text{bad})U(\text{take}, w) \\ &= 0.34 \cdot 20 + 0.66 \cdot 70 = 53 \end{aligned}$$

Optimal decision = take

$$MEU(F = \text{bad}) = \max_a EU(a|\text{bad}) = 53$$

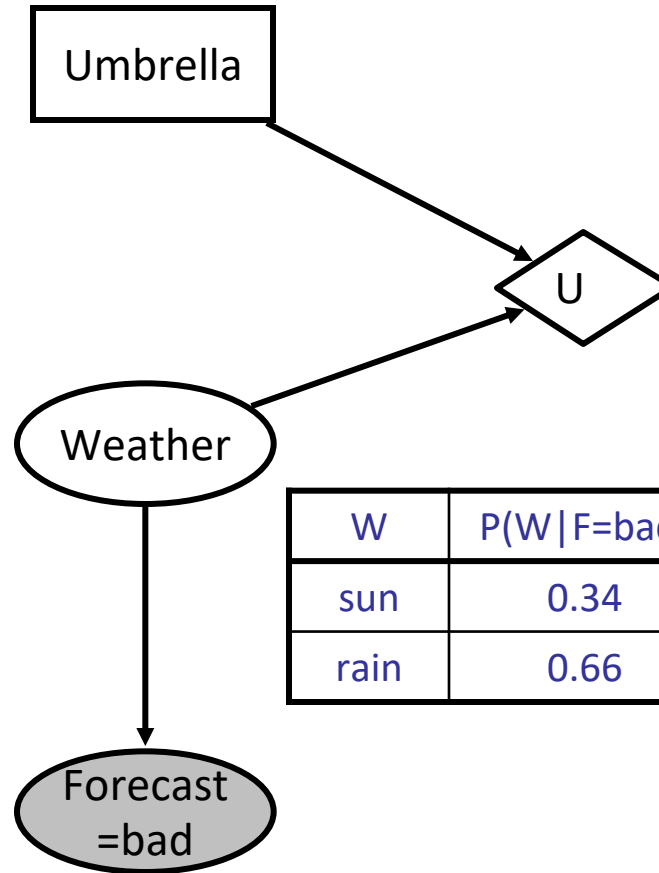

A	W	U(A,W)
leave	sun	100
leave	rain	0
take	sun	20
take	rain	70

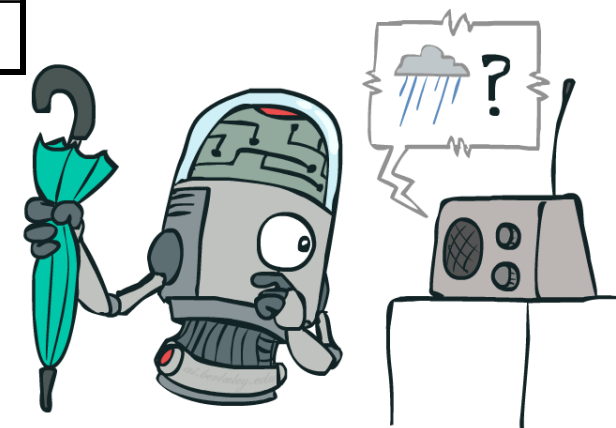

Decisions as Outcome Trees

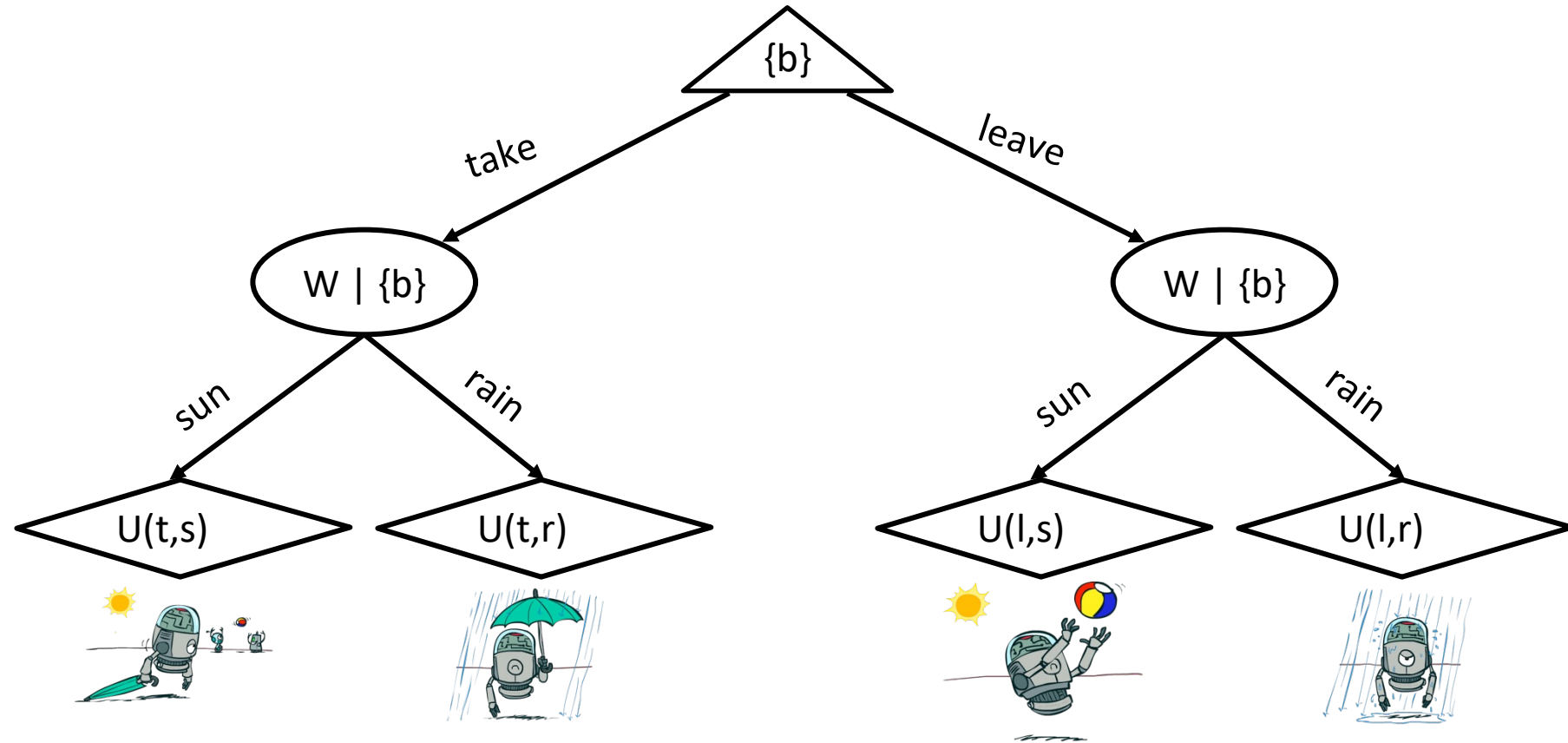
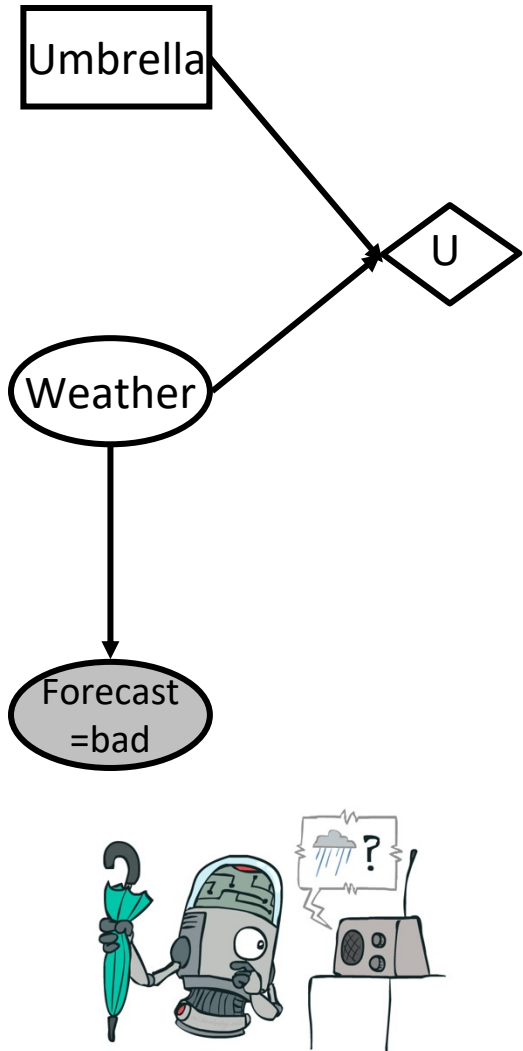

Ghostbusters Decision Network

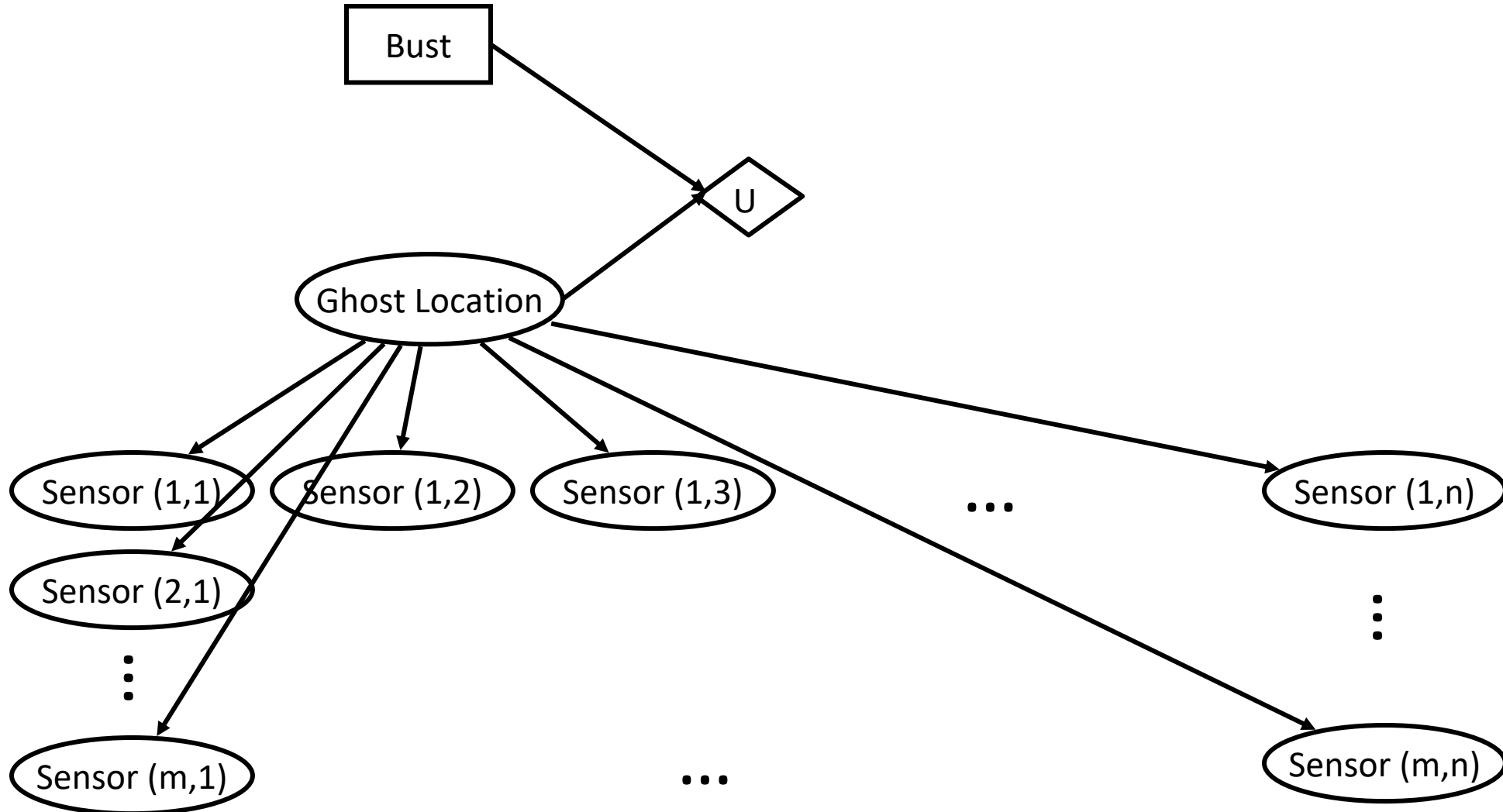

Ghostbusters — Where to measure?

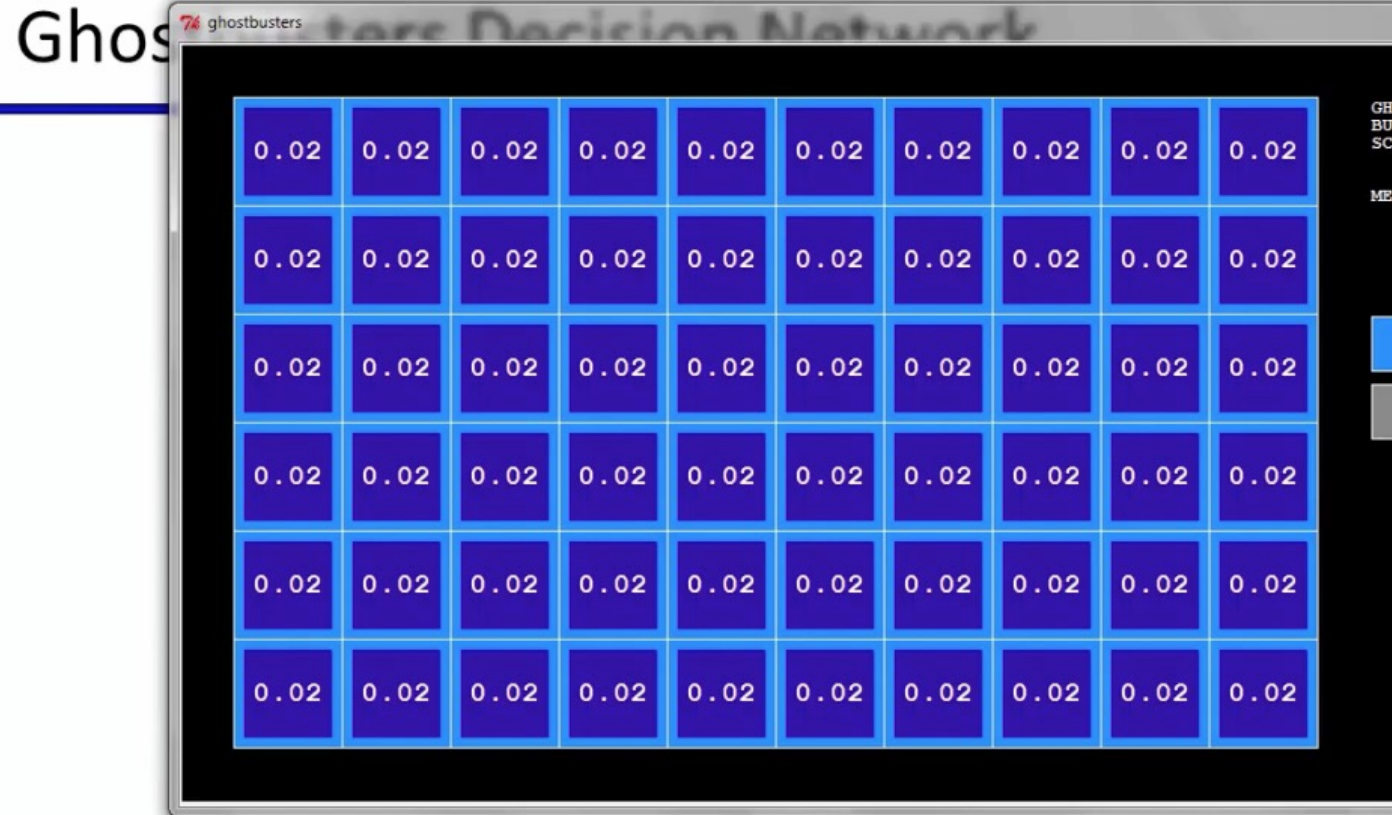

Demo: Ghostbusters

Value of Information

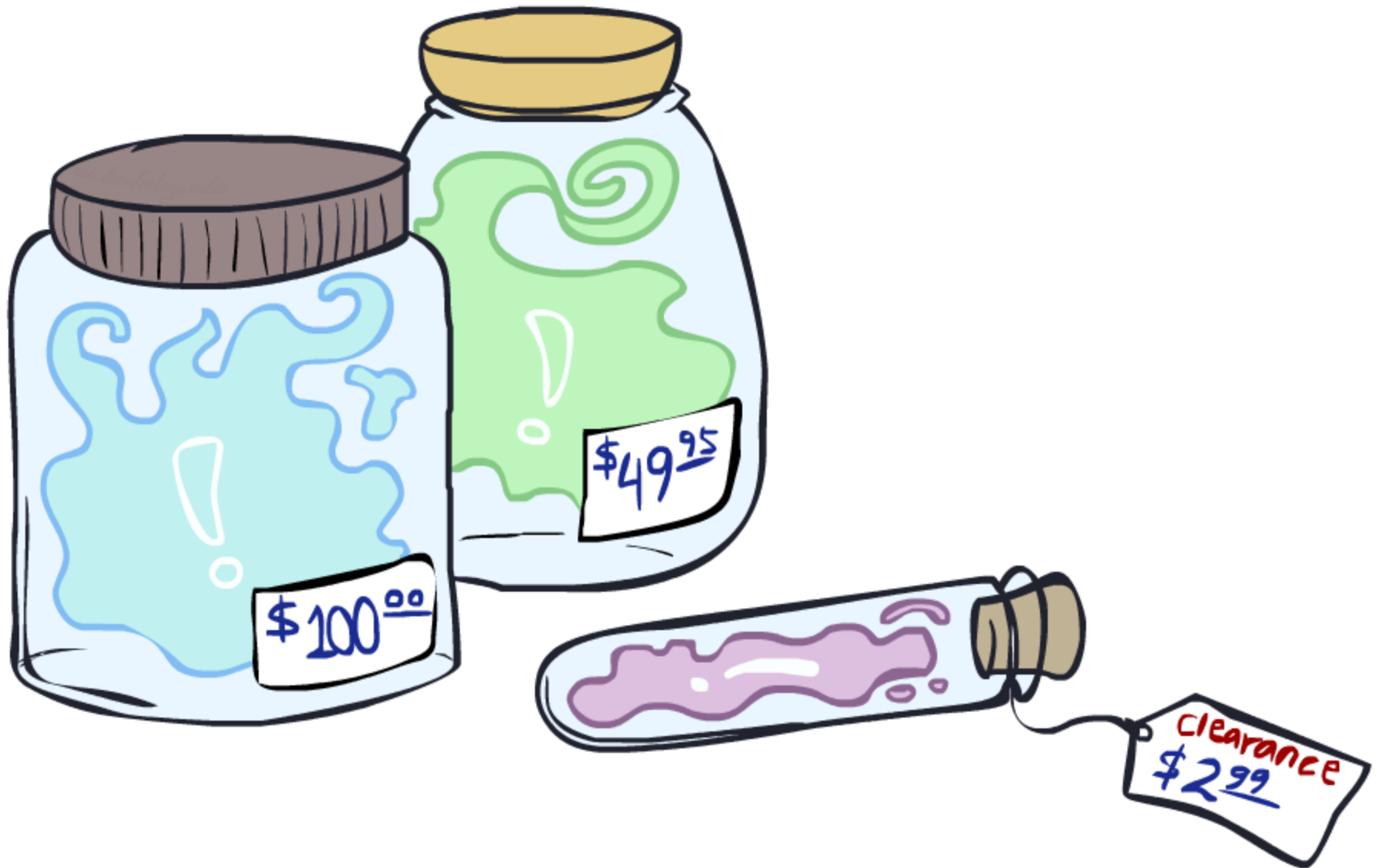

Value of Information

- Idea: compute value of acquiring evidence
 - Can be done directly from decision network
- Example: buying oil drilling rights
 - Two blocks A and B, exactly one has oil, worth k
 - You can drill in one location
 - Prior probabilities 0.5 each, & mutually exclusive
 - Drilling in either A or B has $EU = k/2$, $MEU = k/2$
- Question: what's the value of information of O ?
 - Value of knowing which of A or B has oil
 - Value is expected gain in MEU from new info
 - Survey may say "oil in a" or "oil in b," prob 0.5 each
 - If we know OilLoc, MEU is k (either way)
 - Gain in MEU from knowing OilLoc?
 - $VPI(OilLoc) = k/2$
 - Fair price of information: $k/2$

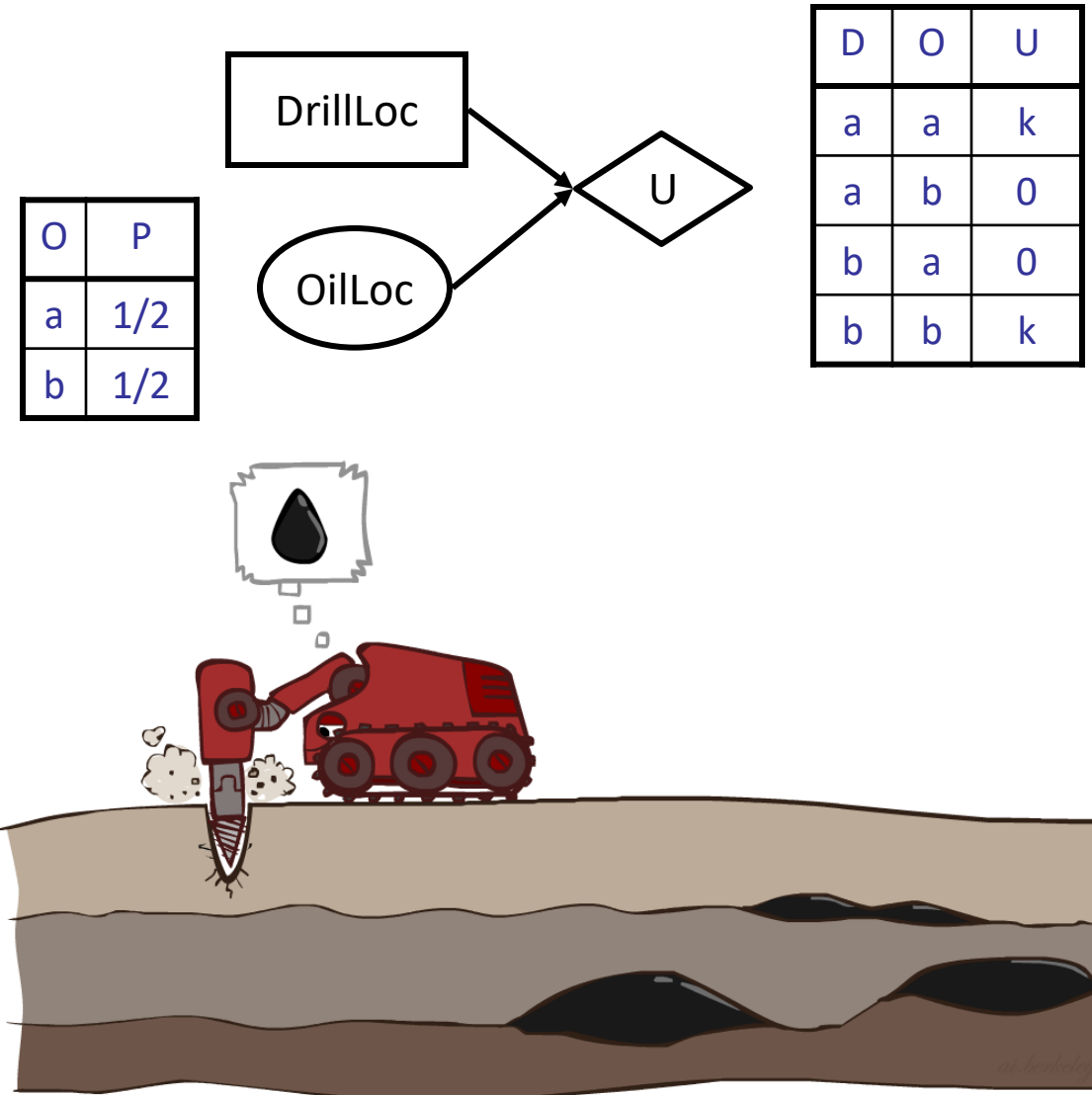

VPI Example: Weather

MEU with no evidence

$$MEU(\emptyset) = \max_a EU(a) = 70$$

MEU if forecast is bad

$$MEU(F = \text{bad}) = \max_a EU(a|\text{bad}) = 53$$

MEU if forecast is good

$$MEU(F = \text{good}) = \max_a EU(a|\text{good}) = 95$$

Forecast distribution

F	P(F)
good	0.59
bad	0.41



$$0.59 \cdot (95) + 0.41 \cdot (53) - 70$$

$$77.8 - 70 = 7.8$$

$$VPI(E'|e) = \left(\sum_{e'} P(e'|e) MEU(e, e') \right) - MEU(e)$$

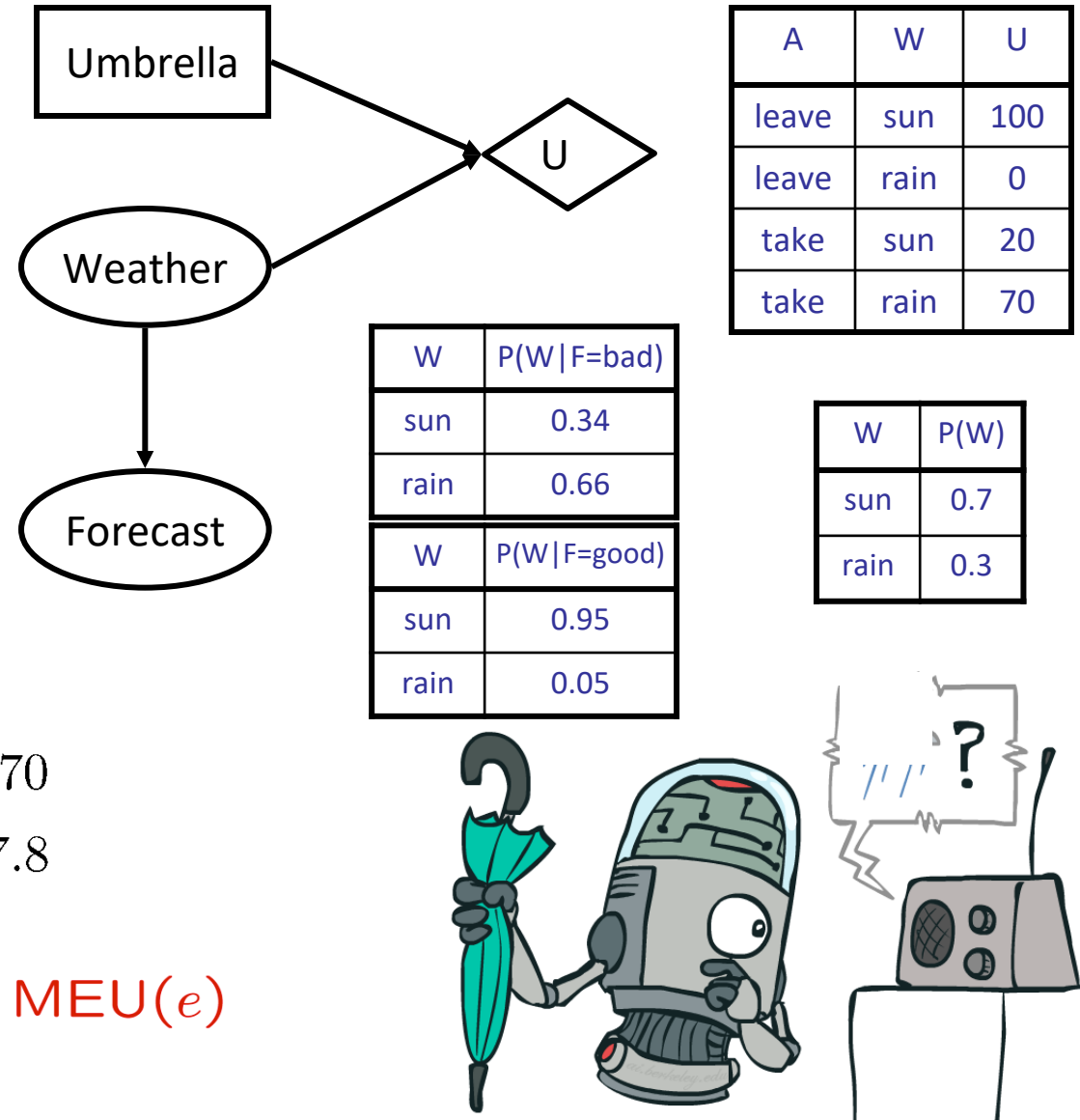

Value of Information

- Assume we have evidence $E=e$. Value if we act now:

$$\text{MEU}(e) = \max_a \sum_s P(s|e) U(s, a)$$

- Assume we see that $E' = e'$. Value if we act then:

$$\text{MEU}(e, e') = \max_a \sum_s P(s|e, e') U(s, a)$$

- BUT E' is a random variable whose value is unknown, so we don't know what e' will be

- Expected value if E' is revealed and then we act:

$$\text{MEU}(e, E') = \sum_{e'} P(e'|e) \text{MEU}(e, e')$$

- Value of information: how much MEU goes up by revealing E' first then acting, over acting now:

$$\text{VPI}(E'|e) = \text{MEU}(e, E') - \text{MEU}(e)$$

VPI Properties

- Nonnegative

$$\forall E', e : \text{VPI}(E'|e) \geq 0$$



- Nonadditive

Typically (but not always):

$$\text{VPI}(E_j, E_k|e) \neq \text{VPI}(E_j|e) + \text{VPI}(E_k|e)$$



- Order-independent

$$\begin{aligned} \text{VPI}(E_j, E_k|e) &= \text{VPI}(E_j|e) + \text{VPI}(E_k|e, E_j) \\ &= \text{VPI}(E_k|e) + \text{VPI}(E_j|e, E_k) \end{aligned}$$

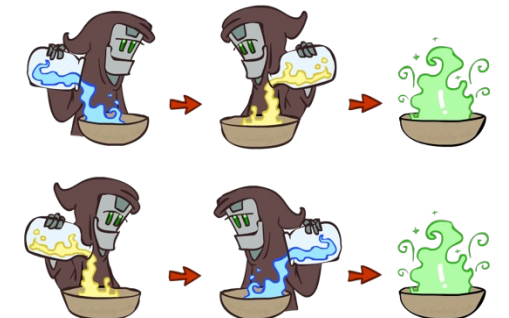

Quick VPI Questions

- The soup of the day is either clam chowder or split pea, but you wouldn't order either one. What's the value of knowing which it is?
- There are two kinds of plastic forks at a picnic. One kind is slightly sturdier. What's the value of knowing which?
- You're playing the lottery. The prize will be \$0 or \$100. You can play any number between 1 and 100 (chance of winning is 1%). What is the value of knowing the winning number?

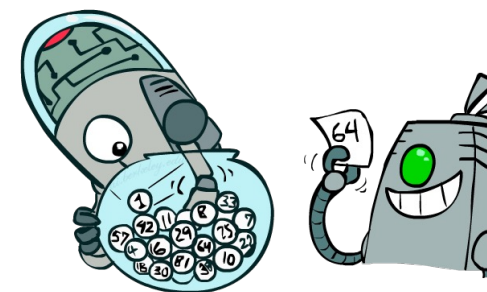
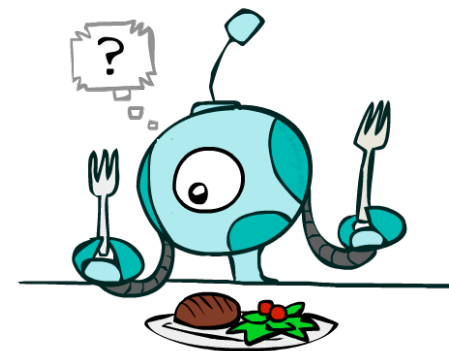
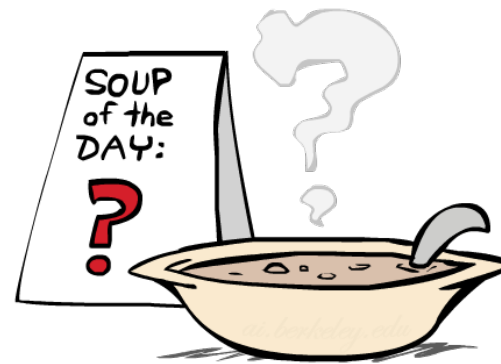

Value of Imperfect Information?



- No such thing
- Information corresponds to the observation of a node in the decision network
- If data is “noisy” that just means we don’t observe the original variable, but another variable which is a noisy version of the original one

VPI Question

- $VPI(\text{OilLoc}) = k/2$
- $VPI(\text{ScoutingReport}) ?$
- $VPI(\text{Scout}) ?$
- $VPI(\text{Scout} \mid \text{ScoutingReport}) ?$

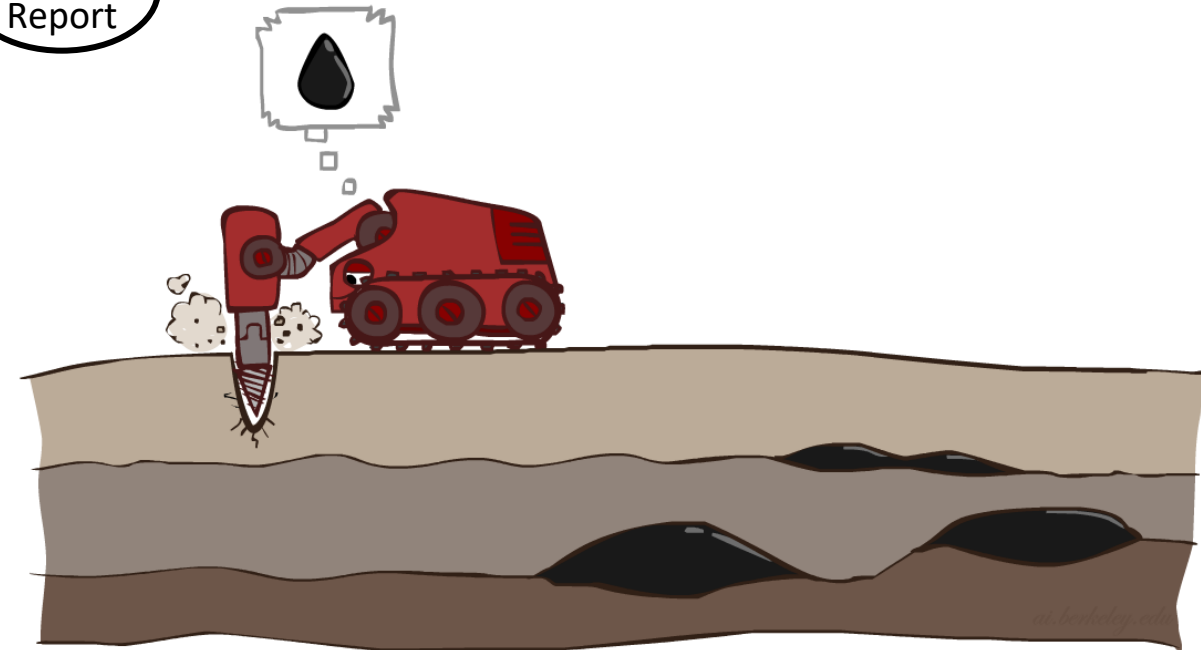
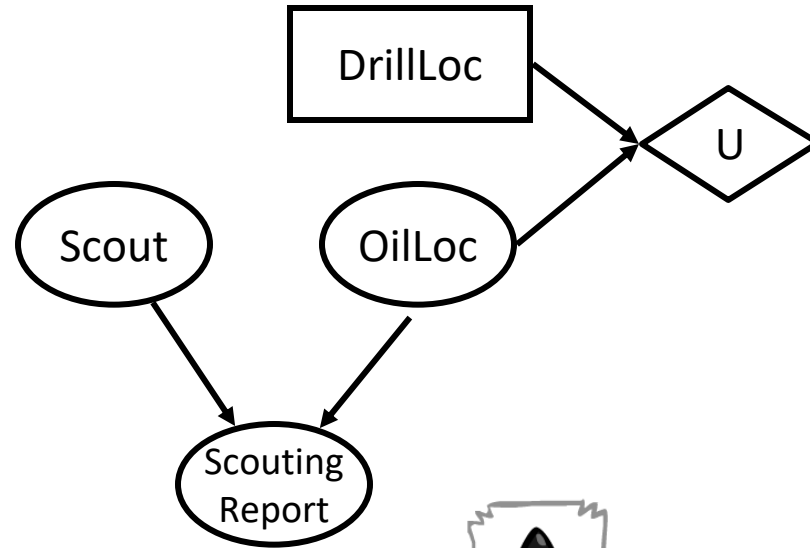

Decision Networks Exercises

It is Monday night, and Bob is finishing up preparing for the CS188 Midterm II that is coming up on Tuesday. Bob has already mastered all the topics except one: Decision Networks. He is contemplating whether to spend the remainder of his evening reviewing that topic (*review*), or just go to sleep (*sleep*). Decision Networks are either going to be on the test ($+d$) or not be on the test ($-d$). His utility of satisfaction is only affected by these two variables as shown below:

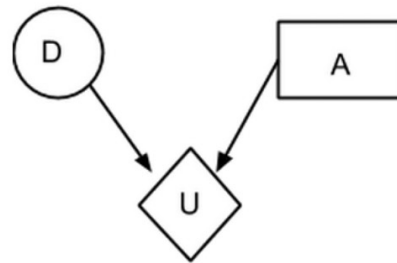

D	P(D)
+d	0.5
-d	0.5

D	A	U(D,A)
+d	<i>review</i>	1000
-d	<i>review</i>	600
+d	<i>sleep</i>	0
-d	<i>sleep</i>	1500

(a) Maximum Expected Utility

Compute the following quantities:

$$EU(\textit{review}) =$$

$$EU(\textit{sleep}) =$$

$$MEU(\{\}) =$$

$$\text{Action that achieves } MEU(\{\}) =$$

Decision Networks Exercises

It is Monday night, and Bob is finishing up preparing for the CS188 Midterm II that is coming up on Tuesday. Bob has already mastered all the topics except one: Decision Networks. He is contemplating whether to spend the remainder of his evening reviewing that topic (*review*), or just go to sleep (*sleep*). Decision Networks are either going to be on the test ($+d$) or not be on the test ($-d$). His utility of satisfaction is only affected by these two variables as shown below:

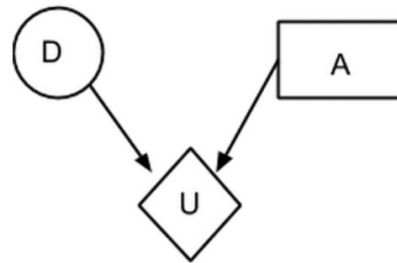

D	P(D)
+d	0.5
-d	0.5

D	A	U(D,A)
+d	<i>review</i>	1000
-d	<i>review</i>	600
+d	<i>sleep</i>	0
-d	<i>sleep</i>	1500

(a) Maximum Expected Utility

Compute the following quantities:

$$EU(\textit{review}) = P(+d)U(+d, \textit{review}) + P(-d)U(-d, \textit{review}) = 0.5 * 1000 + 0.5 * 600 = 800$$

$$EU(\textit{sleep}) = P(+d)U(+d, \textit{sleep}) + P(-d)U(-d, \textit{sleep}) = 0.5 * 0 + 0.5 * 1500 = 750$$

$$MEU(\{\}) = \max(800, 750) = 800$$

$$\text{Action that achieves } MEU(\{\}) = \textit{review}$$

Decision Networks Exercises

The TAs happiness (H) is affected by whether decision networks are going to be on the exam. The happiness (H) determines whether the TA posts on Facebook ($+f$) or doesn't post on Facebook ($-f$). The prior on D and utility tables remain unchanged.

Now consider the case where there are n TAs. Each TA follows the same probabilistic models for happiness (H) and posting on Facebook (F) as in the previous question.

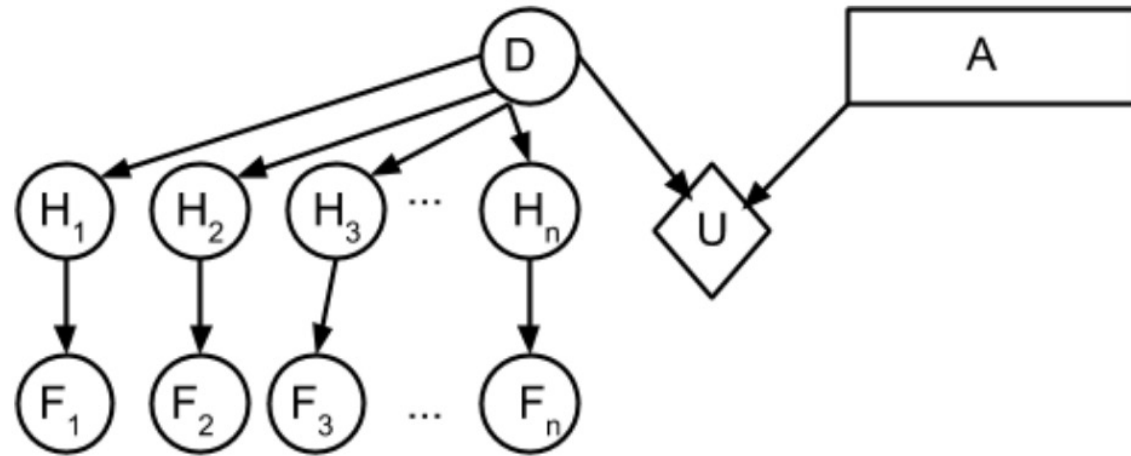

True or False? $VPI(H_1|F_1) = 0$

$VPI(F_1|H_1) = 0$

$VPI(F_3|F_2, F_1) > VPI(F_2|F_1)$

$VPI(F_1, F_2, \dots, F_n) < VPI(H_1, H_2, \dots, H_n)$

Decision Networks Exercises

The TAs happiness (H) is affected by whether decision networks are going to be on the exam. The happiness (H) determines whether the TA posts on Facebook ($+f$) or doesn't post on Facebook ($-f$). The prior on D and utility tables remain unchanged.

Now consider the case where there are n TAs. Each TA follows the same probabilistic models for happiness (H) and posting on Facebook (F) as in the previous question.

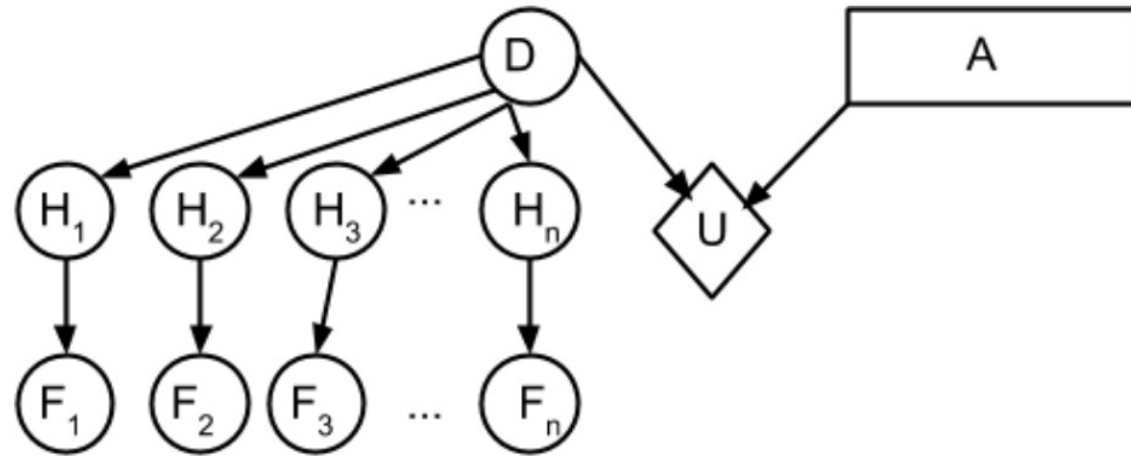

True or False? $VPI(H_1|F_1) = 0$ **False**

$VPI(F_1|H_1) = 0$ **True**

$VPI(F_3|F_2, F_1) > VPI(F_2|F_1)$ **False**

$VPI(F_1, F_2, \dots, F_n) < VPI(H_1, H_2, \dots, H_n)$ **True**